

GREEN VISION WHITE PAPER

VI.04



Green Vision White Paper

• Executive Summary	5
• Introduction: The Climate Challenge	6
• The Urgent Need for Sustainable Solutions	6
• Global Commitments to Carbon Neutrality	6
• Challenges in Current Climate Solutions	6
• Carbon Zero Market Overview	6
• The Opportunity for Innovative Solutions	7
• How Green Vision Addresses the Climate Challenge	7
• Current Problems and Green Vision's Solutions	8
• Problem 1: Lack of Transparency in Carbon Markets	8
• Problem 2: Limited Accessibility for Small Investors	8
• Problem 3: Inefficient Carbon Credit Verification	8
• Problem 4: Environmental Degradation and Unsustainable Practices	8
• Problem 5: Technological Gaps in Traditional Solutions	9
• Market Analysis	10
• Global Carbon Neutrality Trends	10
• Carbon Credit Market	10
• Market Size and Projections	10
• Challenges in the Current Market	10
• Opportunities for Green Vision	10
• Project Concept	11
• Overview	11
• Why Moringa?	11
• Tokenization and NFTs	11
• Land NFTs	11
• Tree NFTs	11
• Process Overview	11
• Revenue Streams	12
• Carbon Credits	12
• Carbon Sequestration by Moringa	12
• Leaf Products	12
• Market Demand	12
• Seed Oils	13
• Benefits	13
• Honey Production	13
• Integration with Beekeeping	13
• Biomass Energy	13
• Renewable Energy Source	13
• Carbon Nanotubes	14
• Innovation in Material Science	14
• Soil Amendment Products (New Revenue Channel)	14
• Biochar Production	14
• Blockchain Integration and GREV Token Issuance	15

Green Vision White Paper

• GREV Token on TRON	15
• BTTC Integration with Climate Combat	15
• Multi-Chain Integration and Ecosystem Expansion	16
• Benefits	16
• Smart Contracts	16
• Core Functions	16
• Security Measures	16
• Cross-Chain Asset Transfers	17
• Green Vision Ecosystem Flowchart	18
• Overview of Green Vision's Ecosystem	18
• Green Vision NFT Marketplace	18
• Overview of the Marketplace	18
• Key Features	19
• Future Updates	19
• Overview	20
• Distribution Process	20
• Tokenomics: Green Vision Token (GREV)	21
• Multi-Chain Token	21
• Total Supply and Distribution	21
• Allocation Breakdown	21
• Vesting Schedule	21
• Governance	21
• Use of Artificial Intelligence (AI)	22
• Operational Efficiency	22
• Predictive Analytics	22
• Blockchain Integration	22
• AI in Product Development	22
• Marketing Plan	23
• Overview	23
• Trending Marketing Strategies	23
• Content Marketing	23
• Social Media Engagement	23
• Influencer Partnerships	23
• Referral Programs	23
• Event Participation	23
• Gamified Marketing: "Climate Combat" Tapping Game	24
• Concept	24
• Integration with Green Vision	25
• Marketing Benefits	25
• Advertising Campaigns	25
• Metrics and Analytics	25
• Investor Benefits	26
• Financial Returns	26
• Environmental Impact	26

Green Vision White Paper

• Transparency and Security	26
• Community Engagement	26
• Risk Management	27
• Market Diversification	27
• Operational Risk Mitigation	27
• Regulatory Compliance	27
• Insurance and Hedging	27
• Partnership Benefits	28
• Introduction to Different Ecosystems	28
• Benefits to Partners	28
• Ecosystem Integration	28
• Real-World Use Cases and Partnerships	29
• Corporate Carbon Offsetting	29
• Sustainable Product Supply	29
• Renewable Energy Projects	29
• Strategic Partnerships	29
• Team	30
• Roadmap	31
• Phase 1: Foundation (Q1 2023)	31
• Phase 2: Whitepaper Launch(Q3 2024)	31
• Phase 3: Token Launch (Q4 2024)	31
• Phase 4: Platform Development (Q1 2025)	31
• Phase 5: Expansion (Q2 2025 - Q4 2025)	31
• Phase 6: Global Scaling (2025 onwards)	31
• Conclusion	32
• Appendix: Glossary of Technical Terms	33
• Frequently Asked Questions (FAQs)	34
• How do I participate in Green Vision?	34
• What makes Moringa trees special for this project?	34
• How are profits distributed to investors?	34
• Is my investment secure?	34
• Can I sell my NFTs?	34
• How does the Climate Combat game fit into the project?	34
• What are the environmental benefits of this project?	34
• How does Green Vision ensure regulatory compliance?	34
• What is the role of AI in Green Vision?	34
• How can I stay updated on project developments?	34
• Footnotes	35

Executive Summary

Green Vision is an innovative blockchain-based project dedicated to combating climate change by integrating sustainable agriculture, advanced technology, and decentralized finance (DeFi). The primary goal of Green Vision is to distribute the revenues generated from Moringa trees back into the ecosystem, thereby supporting not only investors but also farmers and local communities involved in the cultivation process.

The project introduces the Green Vision Token (GREV) as the native utility token of the ecosystem, enabling investors, farmers, and community members to participate in environmentally friendly initiatives centered around the cultivation of Moringa Oleifera—a tree renowned for its exceptional environmental and economic benefits.

By leveraging blockchain technology, Green Vision tokenizes real-world assets (RWA) through Land NFTs and Tree NFTs, representing fractional ownership of land parcels and individual Moringa trees, respectively. These NFTs generate multiple revenue streams including carbon credits, leaf products, seed oils, honey, biomass energy, and more which are distributed throughout the ecosystem to benefit all stakeholders, including farmers who are integral to the cultivation and maintenance of the Moringa trees.

The project has successfully developed a Minimum Viable Product (MVP) by cultivating 4 acres of Moringa trees, demonstrating the feasibility and scalability of the initiative. Through the combination of sustainable agriculture, support for farmers, blockchain technology, AI-driven operational efficiency, and innovative marketing strategies, Green Vision offers a transparent, scalable, and profitable solution to address the global climate crisis while redistributing financial benefits within the ecosystem.

By participating in Green Vision, investors not only gain financial returns but also contribute to meaningful environmental impact and support for farmers. The project stands as a pioneering model for how technology, sustainability, and community involvement can work hand-in-hand to create a better future for both the planet and its people.

Introduction: The Climate Challenge

The Urgent Need for Sustainable Solutions

Climate change is a critical global issue requiring immediate action. Accelerating greenhouse gas (GHG) emissions, particularly carbon dioxide (CO₂), have led to significant increases in global temperatures. The Intergovernmental Panel on Climate Change (IPCC) warns that if current emission rates persist, global temperatures could rise by 1.5°C above pre-industrial levels between 2030 and 2052¹. This rise threatens to trigger severe consequences such as extreme weather events, sea-level rise, biodiversity loss, agricultural disruptions, and health risks.

Global Commitments to Carbon Neutrality

In response to the escalating crisis, over 110 countries have pledged to achieve net-zero emissions by 2050². Governments are implementing policies like carbon pricing and emissions trading systems to reduce GHG emissions. International agreements, notably the Paris Agreement, aim to limit global warming and foster a collective effort towards sustainability.

Challenges in Current Climate Solutions

Despite these commitments, significant challenges hinder progress:

- **Inadequate Scale:** Current efforts are insufficient to meet the targets necessary to mitigate climate change effectively.
- **Lack of Transparency:** Traditional carbon offset projects often lack verifiable data, leading to skepticism and reduced investor confidence.
- **Limited Accessibility:** High entry barriers prevent small investors and developing nations from participating in carbon markets.
- **Technological Limitations:** Failure to leverage modern technologies like blockchain and artificial intelligence (AI) limits efficiency and scalability.

Carbon Zero Market Overview

The carbon market is a vital tool for reducing GHG emissions by assigning a price to carbon and incentivizing low-carbon technologies.

- **Market Growth:** Valued at \$272 billion in 2020, the global carbon offset market is expected to reach \$1,185 billion by 2027, growing at a CAGR of 23.1%³.
- **Corporate Commitments:** Over 1,500 companies have set science-based emission reduction targets⁴.
- **Investment Opportunities:** The voluntary carbon market is poised for significant growth, potentially reaching \$50 billion by 2030⁵.

The Opportunity for Innovative Solutions

There is a clear need for innovative approaches that address existing challenges:

- **Technology Integration:** Utilizing blockchain and AI can enhance transparency, reduce costs, and increase efficiency in carbon markets.
- **Tokenization of Assets:** Tokenizing real-world assets through Non-Fungible Tokens (NFTs) democratizes access to sustainable investments.
- **Community Engagement:** Empowering local farmers and communities promotes sustainable practices and equitable benefit distribution.
- **Scalability and Accessibility:** Lowering barriers to entry enables broader participation from individuals and small investors globally.

How Green Vision Addresses the Climate Challenge

Green Vision offers a comprehensive solution by:

- **Sustainable Agriculture:** Cultivating Moringa Oleifera, a tree with high carbon sequestration capabilities and valuable by-products.
- **Blockchain Transparency:** Implementing blockchain technology ensures immutable and transparent records of transactions and carbon credits.
- **AI-Driven Efficiency:** Utilizing AI for operational optimization, predictive analytics, and risk mitigation enhances scalability.
- **Support for Farmers:** Distributing revenues back into the ecosystem, including farmers and local communities, fosters sustainable development.
- **Accessible Investment:** The use of multi-chain tokens and NFTs lowers investment barriers, allowing global participation.

By addressing the shortcomings of current climate solutions and aligning with market trends, Green Vision provides an innovative and effective approach to combating climate change while offering economic benefits to all stakeholders.



Current Problems and Green Vision's Solutions

Problem 1: Lack of Transparency in Carbon Markets

Issue: Traditional carbon offset projects often lack transparency, leading to distrust among investors and accusations of greenwashing.

Green Vision's Solution:

- **Blockchain Transparency:** Immutable records of carbon credits and transactions.
- **Smart Contracts:** Automated verification and execution of carbon credit generation and distribution.
- **Real-Time Data:** AI and IoT sensors provide up-to-date information on carbon sequestration.

Problem 2: Limited Accessibility for Small Investors

Issue: High entry barriers prevent small investors and developing regions from participating in carbon markets and sustainable investments.

Green Vision's Solution:

- **Tokenization:** Fractional ownership through NFTs lowers investment thresholds.
- **Decentralized Platform:** Accessible globally without the need for intermediaries.
- **Gamified Marketing:** Engages a broader audience through interactive platforms, allowing users to earn tokens and NFTs.

Problem 3: Inefficient Carbon Credit Verification

Issue: Manual verification processes are time-consuming, costly, and prone to errors.

Green Vision's Solution:

- **AI Verification:** Automated monitoring and data collection for accurate carbon credit calculations.
- **Third-Party Certification Integration:** Seamless collaboration with certification bodies via blockchain.

Problem 4: Environmental Degradation and Unsustainable Practices

Issue: Deforestation and unsustainable agriculture contribute significantly to carbon emissions and biodiversity loss.

Green Vision's Solution:

- **Sustainable Moringa Cultivation:** Promotes reforestation and soil improvement.
- **Community Involvement:** Engages local communities in sustainable practices, providing economic opportunities.
- **Biodiversity Support:** Moringa plantations support local ecosystems and wildlife.

Problem 5: Technological Gaps in Traditional Solutions

Issue: Lack of integration with modern technologies hinders the efficiency and scalability of environmental projects.

Green Vision's Solution:

- Blockchain Integration: Enhances efficiency, security, and transparency.
- AI and IoT: Optimizes operations, reduces costs, and improves environmental impact.
- Multi-Chain Token: GREV is a multi-chain token, ensuring scalability and accessibility across different blockchain ecosystems



Market Analysis

Global Carbon Neutrality Trends

- **Policy Shifts:** Governments worldwide are implementing policies to reduce carbon emissions, such as carbon taxes and emission trading systems.
- **Corporate Responsibility:** Companies are increasingly accountable for their carbon footprints, influencing investor and consumer decisions.
- **Technological Advancements:** Innovations in renewable energy, carbon capture, and sustainable agriculture are driving market growth.

Carbon Credit Market

- **Compliance Markets:** Governed by mandatory national, regional, or international carbon reduction regimes.
- **Voluntary Markets:** Allow businesses and individuals to purchase carbon offsets on a voluntary basis.

Market Size and Projections

- **Compliance Market:** Reached \$261 billion in value in 2020.
- **Voluntary Market:** Expected to grow to \$50 billion by 2030.

Challenges in the Current Market

- **Verification Issues:** Manual verification processes lead to delays and increased costs.
- **Market Fragmentation:** Lack of standardization across markets complicates trading.
- **Accessibility Barriers:** Small investors and developing countries often lack access to carbon markets.

Opportunities for Green Vision

- **Blockchain Integration:** Enhances transparency and efficiency in carbon credit trading.
- **Tokenization:** Lowers entry barriers, allowing wider participation.
- **Sustainable Agriculture:** Taps into the growing demand for eco-friendly products.

Project Concept

Overview

At the core of Green Vision is the cultivation of Moringa Oleifera, a fast-growing, drought-resistant tree known for its exceptional carbon sequestration capabilities and versatile commercial applications. The project tokenizes land and Moringa trees through NFTs, allowing investors to own fractional shares of these assets and benefit from multiple revenue streams.

Why Moringa?

- High Carbon Sequestration: Moringa trees can sequester up to 20 times more CO₂ than general vegetation⁷.
- Fast Growth: They reach maturity within 6-8 months, enabling rapid carbon credit generation.
- Versatile Products: Leaves, seeds, and pods are used in food, medicine, cosmetics, and biofuels.
- Environmental Benefits: Improve soil quality, prevent erosion, and support biodiversity.

Tokenization and NFTs

Land NFTs

- Representation: Fractional ownership of land parcels dedicated to Moringa cultivation.
- Benefits: Entitle holders to a share of revenues from all activities on the land, including carbon credits and product sales.

Tree NFTs

- Representation: Ownership of individual Moringa trees.
- Benefits: Allow holders to earn profits from the specific tree's yield and carbon credits.

Process Overview:

- Acquire GREV Tokens: Investors purchase GREV tokens via token sales.
- Mint NFTs: Use GREV tokens to mint Land and Tree NFTs through smart contracts.
- Profit Generation: NFTs generate revenue from various streams tied to Moringa cultivation.
- Profit Distribution: Earnings are distributed in stablecoins (e.g., USDT) proportionally to NFT holdings.
- Secondary Market: NFTs can be traded on decentralized marketplaces, providing liquidity.

Revenue Streams

Green Vision's diversified revenue model ensures sustainable financial returns for investors while maximizing environmental impact.

Carbon Credits

Carbon Sequestration by Moringa

- High Efficiency: Moringa trees sequester up to 5 metric tons of CO₂ per hectare per year.
- Certification: Carbon credits are verified by international bodies like the Gold Standard or Verified Carbon Standard (VCS).

Mathematical Model

$$\text{Carbon Credits}(t) = a \times \text{Number of Trees}(t)$$

Where : • a = Average carbon sequestration per tree per year.

Leaf Products

Market Demand

- Nutritional Value: Moringa leaves are rich in vitamins, minerals, and antioxidants.
- Applications: Used in dietary supplements, health foods, and cosmetics.
- Market Growth: The global superfoods market is projected to reach \$209 billion by 2025.

Revenue Calculation

$$\text{Leaf Revenue}(t) = \beta \times \text{Leaf Yield}(t) \times \text{Market Price}$$

Where : Efficiency factor in processing and sales.



Seed Oils

Benefits

- High-Quality Oil: Moringa seeds yield ben oil, used in cosmetics and as a lubricant.
- Global Market: Growing demand for natural oils in the beauty industry.

Revenue Calculation

Oil Revenue(t) = $y \times \text{Seed Yield}(t) \times \text{Market Price}$

Where

- y : Extraction efficiency.

Honey Production

Integration with Beekeeping

- Animal-Friendly Beekeeping: Green Vision uses bio-organic, sustainable practices that avoid harming bee populations, ensuring colony health and natural growth.
- Sustainability Focus: Beekeeping practices are designed to support the ecosystem, aligning with Green Vision's commitment to ethical and eco-friendly operations.

Revenue Calculation

Honey Revenue(t) = $S \times \text{Beehive Count} \times \text{Honey Yield per Hive} \times \text{Market Price}$

Where:

- S = Beekeeping efficiency factor.

Biomass Energy

Renewable Energy Source

- Sustainable Fuel: Moringa biomass can be converted into biofuel.
- Energy Demand: Aligns with global shifts towards renewable energy sources.

Revenue Calculation

Biomass Revenue(t) = $\epsilon \times \text{Biomass Yield}(t) \times \text{Energy Conversion Rate} \times \text{Market Price}$

Where:

- ϵ = Conversion efficiency.

Carbon Nanotubes

Innovation in Material Science

- **Application:** Moringa-derived biomass can be used to produce carbon nanotubes.
- **Market Potential:** Used in electronics, construction, and medicine.
- **Market Size:** The global carbon nanotubes market is expected to reach \$10.52 billion by 2028, growing at a CAGR of 14.9%¹⁰.

Revenue Calculation

Nanotube Revenue(t) = (x Biomass Yield(t) × Production Efficiency × Market Price

Where : = (Production efficiency

Soil Amendment Products (New Revenue Channel)

Biochar Production

- **Soil Health:** Biochar improves soil fertility and water retention.
- **Environmental Impact:** Sequesters carbon in the soil.
- **Market Growth:** The global biochar market is projected to reach \$3.1 billion by 2025.

Revenue Calculation

Biochar Revenue(t) = n × Biomass Residue(t) × Market Price

Where : n = Biochar conversion efficiency.



Blockchain Integration and GREV Token Issuance

Green Vision leverages the TRON blockchain to support fast, secure transactions and ensure transparency in all aspects of its operations, from afforestation to carbon credit distribution. By utilizing blockchain technology, we provide real-time tracking of tree growth, environmental impact, and revenue distribution through Tree NFTs. Our token ecosystem is designed for scalability and efficiency to support the long-term sustainability of our mission.

GREV Token on TRON

The GREV Token serves as the utility token for Green Vision's ecosystem, enabling the purchase of Tree NFTs, carbon credit transactions, and profit-sharing mechanisms. The total supply is 2 billion tokens, issued on the TRC-20 standard of the TRON blockchain. GREV ensures low-cost, high-speed transactions within the ecosystem.

Total Supply 2,000,000,000 × 10

18

Smart contracts built on TRON automate the distribution of revenue from carbon credits and Moringa product sales to stakeholders, including local farmers. These contracts guarantee secure, immutable, and efficient financial transactions.

BTTC Integration with Climate Combat

BTTC (BitTorrent Chain) is integrated exclusively with the Climate Combat game to enhance user engagement. In this game, users will receive BTTC airdrops as rewards, promoting both TRON and BTTC ecosystems. The BTTC airdrops encourage active participation and growth within the Green Vision community.

The cross-chain functionality provided by BTTC is focused on game rewards and does not directly involve GREV tokens or Tree NFTs. This integration is aimed at driving community engagement while supporting real-world environmental actions through the game.

Transaction Fee Formula :

Transaction Fee = Gas Price x Gas Limit

This formula calculates the cost for GREV transfers across chains, ensuring efficient and cost-effective transactions within the Climate Combat.



Multi-Chain Integration and Ecosystem Expansion

Green Vision is committed to building a multi-chain ecosystem to enhance scalability and global reach. In addition to TRON and BTTC, the GREV token will be bridged to other Layer 1 blockchains such as Ethereum, Polygon, Solana, XDC, Diamante and Avalanche. This multi-chain integration will enable broader access to Green Vision's platform, allowing users across various blockchain ecosystems to engage in carbon credit trading and afforestation initiatives. The bridging functionality will ensure that GREV tokens and Tree NFTs remain tradable across multiple blockchains, expanding liquidity and user participation.

By employing a multi-chain approach, Green Vision aims to position itself as a leader in the blockchain-based sustainability sector, providing a transparent, scalable, and efficient platform for afforestation and carbon credit distribution.

Benefits

- **Scalability:** Expands across multiple blockchains to distribute transactions, reducing network congestion.
- **Cost-Efficiency:** Selects low-gas networks for transactions, minimizing costs.
- **Interoperability:** Enables cross-chain transfers, allowing assets to move seamlessly between blockchains.
- **Accessibility:** Empowers users from various blockchain ecosystems to participate effortlessly in Green Vision's platform.

Smart contracts built on TRON automate the distribution of revenue from carbon credits and Moringa product sales to stakeholders, including local farmers. These contracts guarantee secure, immutable, and efficient financial transactions.

Smart Contracts

Core Functions

- **NFT Minting:** Automated creation of Land and Tree NFTs upon staking GREV tokens.
- **Profit Distribution:** Smart contracts execute periodic profit-sharing in stablecoins.
- **Governance:** Facilitate decentralized decision-making through voting mechanisms.

Security Measures

- **Audits:** Regular smart contract audits by reputable firms.
- **Upgradability:** Implement proxy patterns for contract upgrades without disrupting the ecosystem.



Cross-Chain Asset Transfers

As part of Green Vision's plan for a multi-chain ecosystem, we are implementing Cross-Chain Asset Transfers to ensure the seamless movement of GREV tokens and Tree NFTs across various blockchains like Ethereum, Polygon, Solana, and Avalanche. This will expand the ecosystem's accessibility and liquidity.

We utilize cross-chain bridges to allow users to transfer assets between these blockchains. Below is a specialized code reference for a simple cross-chain transfer using Ethereum and TRON:

```
pragma solidity ^0.8.0;

interface ITRC20 {
    function transfer(address _to, uint256 _value) external returns (bool);
}

contract CrossChainBridge {
    address public ethereumBridge;
    address public tronBridge;

    event TokenBridged(address indexed user, uint256 amount, string chain);

    function bridgeToTRON(uint256 amount) public {
        require(ITRC20(ethereumBridge).transfer(address(this), amount), "Transfer failed");
        emit TokenBridged(msg.sender, amount, "TRON");
    }

    function bridgeToEthereum(uint256 amount) public {
        require(ITRC20(tronBridge).transfer(address(this), amount), "Transfer failed");
        emit TokenBridged(msg.sender, amount, "Ethereum");
    }
}
```

This allows for seamless token bridging between Ethereum and TRON, and similar methods will be employed for other supported blockchains to enable smooth asset transfers.



Green Vision Ecosystem Flowchart

Overview of Green Vision's Ecosystem

The following flowchart illustrates the entire process of how users interact with the Green Vision ecosystem, including GREV token acquisition, NFT minting, Moringa cultivation, revenue generation, and carbon credit trading. The diagram also shows how farmers benefit from revenue sharing and how users can enter the ecosystem through the Climate Combat game or by purchasing GREV tokens directly.

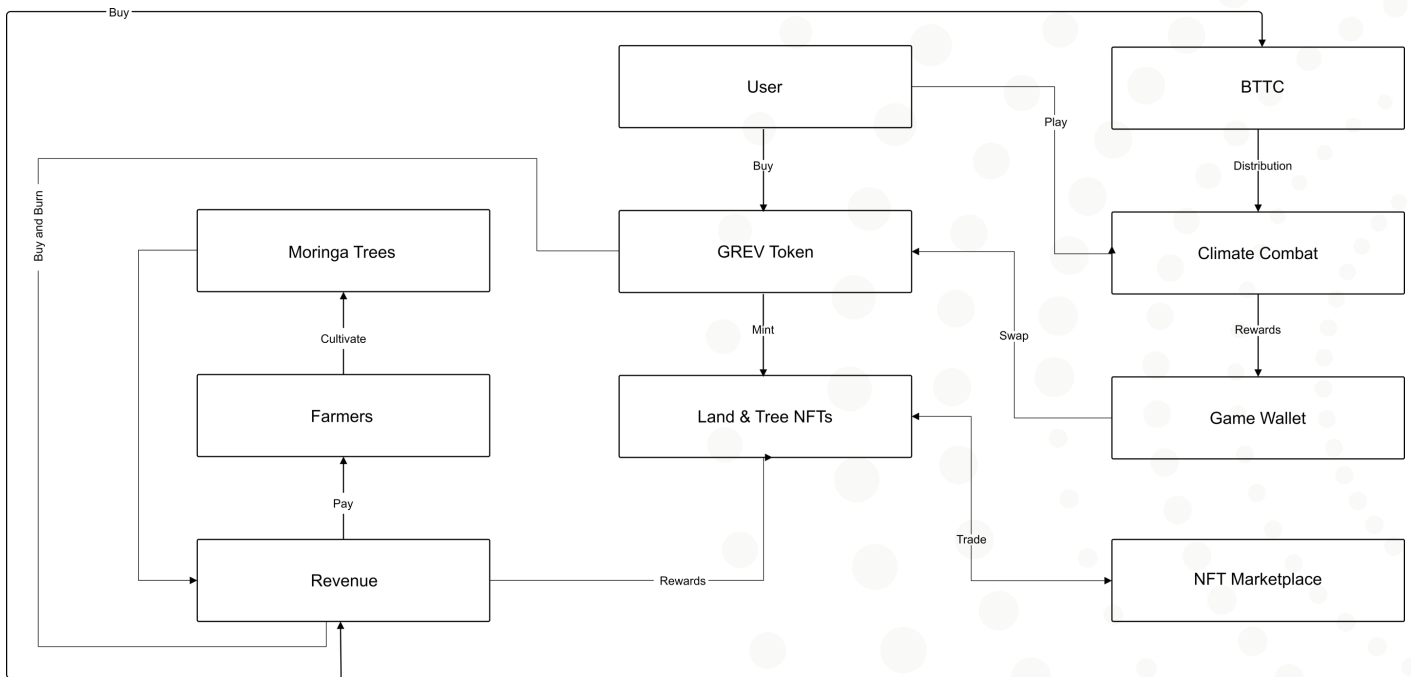

Green Vision NFT Marketplace

Overview of the Marketplace

Green Vision has developed a dedicated NFT marketplace to enable the seamless trading of Land and Tree NFTs. This marketplace acts as the central hub for users to mint, trade, and manage their NFTs, representing fractional ownership in the project's Moringa plantations and carbon credit-generating assets.

The marketplace is currently available as a demo version and can be accessed via the following link: <https://greenvision.eco/nft>. It showcases the functionality of NFT trading within the ecosystem and integrates both GREV tokens and carbon credits as key elements of the trading process.

Key Features:

- **Minting NFTs:** Users can mint Land and Tree NFTs by purchasing GREV tokens, which represent their ownership stake in Moringa trees and the carbon credits generated.
- **Trading Platform:** The marketplace facilitates the buying and selling of these NFTs, ensuring liquidity and user engagement. NFTs can also be traded between users, providing a dynamic and transparent marketplace.
- **Carbon Credit Integration:** The marketplace not only supports the trade of NFTs but also integrates carbon credits generated by Moringa trees. Users can trade these credits alongside their NFTs, contributing to the broader carbon offset economy.
- **User Wallet Integration:** The NFT marketplace integrates with users' digital wallets, allowing them to securely store their NFTs and participate in the ecosystem.

Future Updates:

As the marketplace transitions from its demo version to the full launch, additional features such as expanded trading capabilities, rewards, and cross-chain NFT trading will be implemented, further enhancing the platform's usability and scalability.

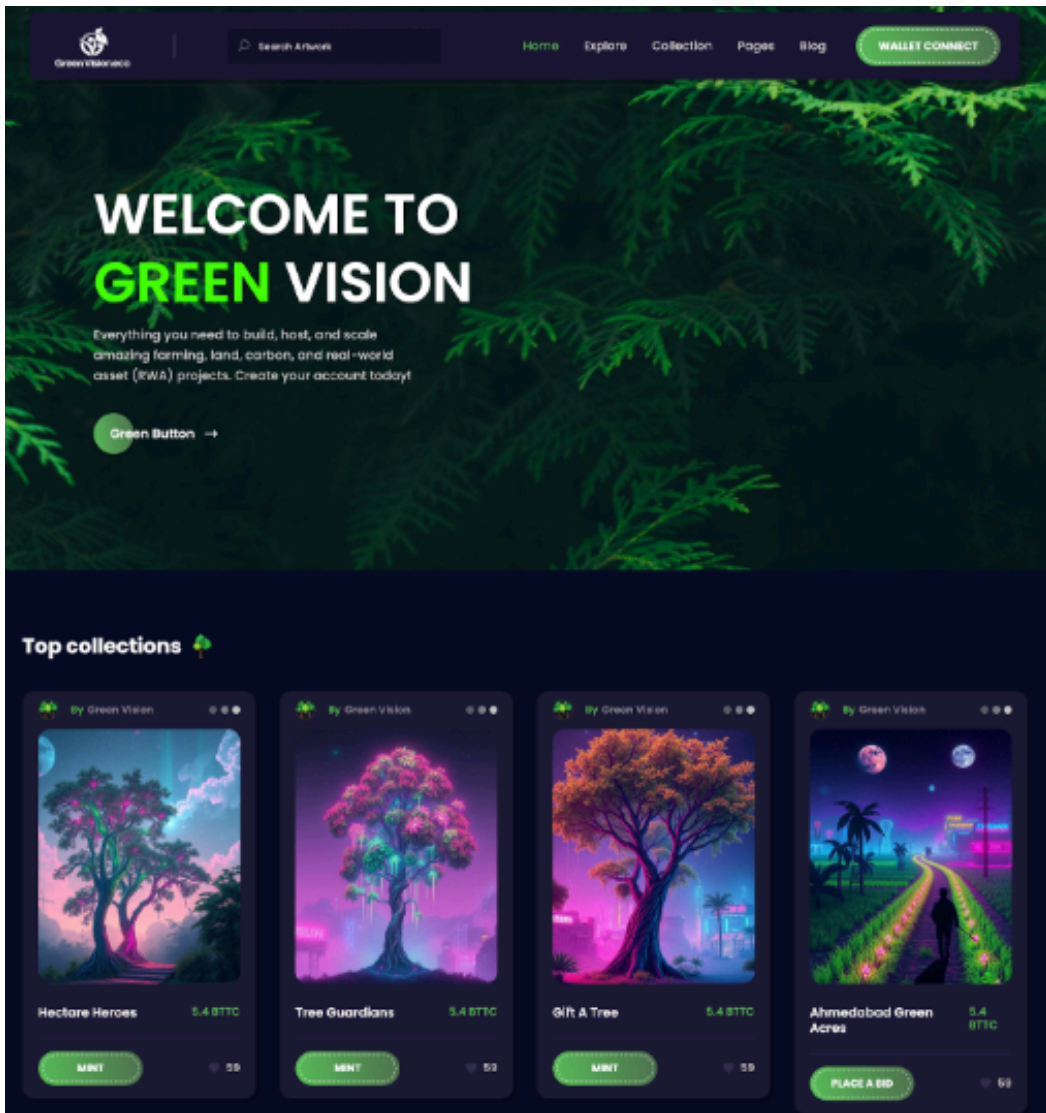

8. Profit-Sharing Mechanism

Overview

Profits generated from all revenue streams are pooled and distributed to NFT holders based on their fractional ownership.

Mathematical Model

$$P_{\text{holder}}(t) = \frac{NFT_{\text{holder}}}{NFT_{\text{total}}} \times \left(\sum_{k=1}^n R_k(t) \right)$$

Where:

$P_{\text{holder}}(t)$ = Profit for the holder at time t.

NFT_{holder} = Number of NFTs held.

NFT_{total} = Total NFTs in circulation.

$R_k(t)$ = Revenue from stream k at time t.

n = Total number of revenue streams.

Distribution Process

- **Frequency:** Profits are distributed quarterly.
- **Currency:** Distributed in stablecoins (e.g., USDT) to ensure value stability.
- **Automation:** Executed via smart contracts to ensure transparency and timeliness.



Tokenomics: Green Vision Token (GREV)

Multi-Chain Token

The GREV token is multi-chain, available across multiple blockchain networks to enhance accessibility and interoperability.

Total Supply and Distribution

- Total Issuance: 2,000,000,000 GREV

Allocation Breakdown

Seed & Private Investors	20,000,000	1%
Private Sale	40,000,000	2%
Public Sale	80,000,000	4%
Eco Fund	200,000,000	10%
Founders	200,000,000	10%
Advisors	100,000,000	5%
Liquidity	200,000,000	10%
Treasury Reserve	600,000,000	30%
Marketing	200,000,000	10%
Airdrop	60,000,000	3%
Development	100,000,000	5%
Strategic Partnership	200,000,000	10%
Total	2,000,000,000	100%

Vesting Schedule

- Team & Founders: 12 month cliff, 24-month linear vesting.
- Advisors: 6-month cliff, 6 month cliff, 12 month linear vesting.
- Angel, Public, Private Sale Investors: 3 month lock-up, 12 month linear vesting.

Governance

GREV token and/or NFT holders participate in platform governance through a Decentralized Autonomous Organization (DAO) structure.

- Voting Rights: Proportional to GREV and/or NFT holdings.
- Proposals: Changes to platform features, revenue allocation, partnerships, etc.

Use of Artificial Intelligence (AI)

Operational Efficiency

- **Automated Monitoring:** AI-driven drones and IoT sensors monitor tree health, soil conditions, and growth rates.
- **Data Analytics:** Real-time data feeds optimize irrigation, fertilization, and harvesting schedules.
- **AI-Enabled Predictive Maintenance:** Predict equipment failures in processing facilities to minimize downtime.

Predictive Analytics

- **Risk Mitigation:** AI models forecast environmental risks like droughts or pest infestations.
- **Yield Optimization:** Predict optimal planting cycles to maximize biomass and product yields.
- **Market Forecasting:** AI algorithms analyze market trends for Moringa products and carbon credits to inform strategic decisions.

Blockchain Integration

- **Smart Contract Triggers:** AI data feeds initiate smart contract events (e.g., profit distribution) based on predefined conditions.
- **Data Verification:** AI ensures data integrity for carbon credit calculations, enhancing transparency.

AI in Product Development

- **Product Quality Control:** AI systems analyze product quality in real-time during processing.
- **Research and Development:** Machine learning models assist in developing new Moringa-based products.



Marketing Plan

Overview

Green Vision's marketing strategy aims to build brand awareness, engage the community, and drive investor participation through a combination of traditional and innovative digital marketing techniques

Trending Marketing Strategies

Content Marketing

- Educational Content: Publish articles, technical documentations, and videos on sustainability, blockchain, and Moringa benefits.
- Thought Leadership: Position Green Vision as an authority in sustainable blockchain projects

Social Media Engagement

- Platforms: Active presence on Twitter/X, LinkedIn, Instagram, and Telegram.
- Community Building: Host AMA (Ask Me Anything) sessions and live streams with the founding team

Influencer Partnerships

- Blockchain Influencers: Collaborate with key opinion leaders in the crypto space.
- Environmental Advocates: Partner with eco-conscious influencers to reach a broader audience

Referral Programs

Incentivization: Offer GREV token rewards for referrals and participation in platform activities.

Event Participation

- Conferences and Webinars: Present at industry events related to blockchain, sustainability, and agriculture.
- Workshops: Host online and offline workshops to educate potential investors and partners.



Gamified Marketing: "Climate Combat" Tapping Game

Concept

- Engagement Tool: A mobile tapping game designed to raise environmental awareness and engage users in a fun, interactive way.
- Gamification: Players complete environmental missions and challenges, earning points and rewards

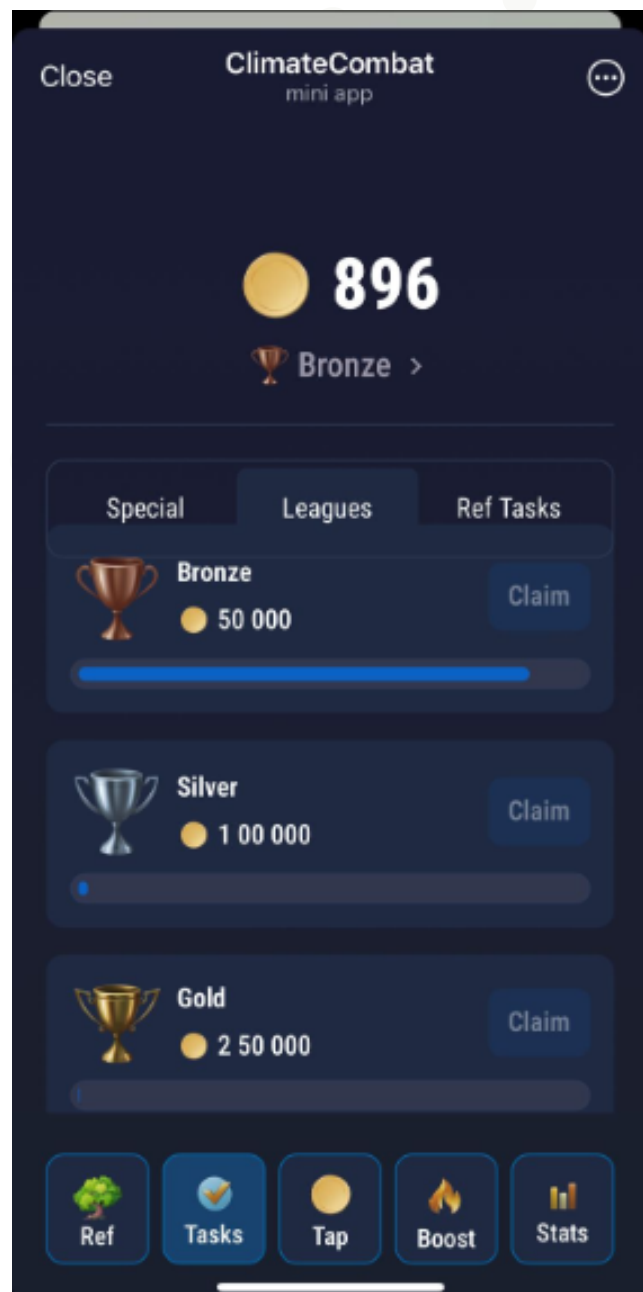
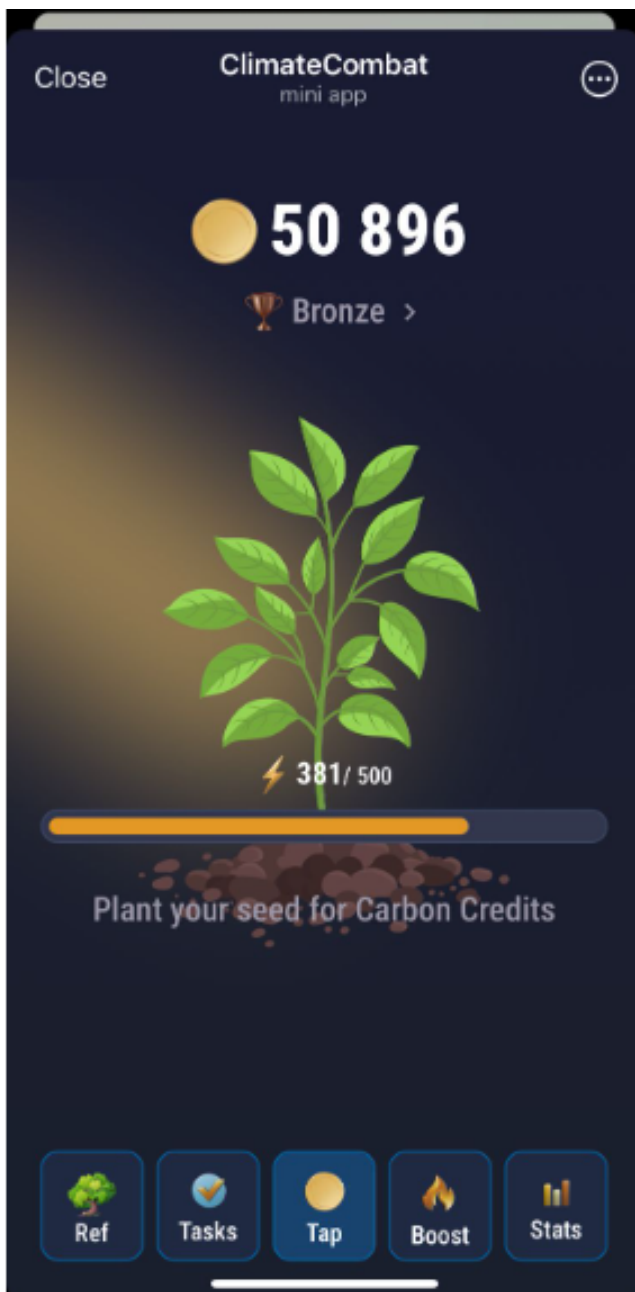

Integration with Green Vision

- GREV Token Rewards: Players earn GREV tokens for in-game achievements, which can be used within the Green Vision ecosystem.
- NFT Collectibles: Special in-game items can be minted as NFTs, providing an introduction to blockchain technology.
- Community Building: Encourages user participation and spreads awareness through social sharing features.

Marketing Benefits

- Viral Potential: The game's engaging nature encourages sharing and organic growth.
- Educational Platform: Serves as a medium to educate users about climate change and Green Vision's mission.

Advertising Campaigns

- Digital Ads: Targeted ads on platforms like Google Ads, Facebook Ads, and crypto-specific websites.
- Press Releases: Distribute news to major media outlets and industry publications.
- Sponsored Content: Collaborate with blogs and online magazines for sponsored articles.

Metrics and Analytics

Key Performance Indicators (KPIs):

- Website traffic and engagement
- Social media followers and engagement
- Conversion rates from marketing campaigns
- User acquisition and retention rates for the Climate Combat game

Data-Driven Decisions: Utilize analytics tools to monitor performance and adjust strategies accordingly.



Investor Benefits

Financial Returns

- Multiple Revenue Streams: Diversification reduces risk and enhances profitability.
- Asset Liquidity: NFTs can be traded, providing flexibility and potential capital gains.

Environmental Impact

- Carbon Offsetting: Direct contribution to CO₂ reduction.
- Sustainable Development: Support for eco-friendly products and renewable energy

Transparency and Security

- Blockchain Assurance: Immutable records and smart contracts ensure trust.
- Regulatory Compliance: Adherence to international standards enhances legitimacy.

Community Engagement

- Governance Participation: Influence project direction through voting.
- Educational Opportunities: Access to insights on sustainable practices and blockchain technology.



Risk Management

Market Diversification

- Multiple Revenue Streams: Mitigates dependency on a single market or product.
- Global Market Access: Selling products and carbon credits in diverse markets reduces regional risk.

Operational Risk Mitigation

- AI Monitoring: Early detection of potential issues reduces downtime and losses.
- Supply Chain Resilience: Multiple suppliers and distribution channels ensure continuity.

Regulatory Compliance

- Environmental Standards: Aligning with international protocols like the Paris Agreement.
- Financial Regulations: Compliance with KYC/AML policies to legal requirements.

Insurance and Hedging

- Crop Insurance: Protects against natural disasters.
- Financial Instruments: Hedging strategies to manage commodity price fluctuations.



Partnership Benefits

Introduction to Different Ecosystems

Green Vision aims to establish strategic partnerships across various industries and ecosystems to enhance its reach, scalability, and impact.

Benefits to Partners

- **Access to Carbon Credits:** Corporations can offset their carbon footprints efficiently.
- **Supply Chain Integration:** Manufacturers gain a reliable source of high-quality Moringa products.
- **Technological Collaboration:** Tech firms can integrate their solutions into a real-world application, showcasing their capabilities.
- **Market Expansion:** Partners can tap into new markets through Green Vision's global network.
- **Brand Enhancement:** Associating with a sustainable initiative enhances corporate social responsibility profiles.

Ecosystem Integration

- **Blockchain Ecosystems:** Collaboration with multiple blockchain networks ensures interoperability and wider user adoption.
- **Agricultural Networks:** Partnerships with agricultural organizations promote sustainable farming practices.
- **Environmental Organizations:** Working with NGOs (Non-Government Organizations) and conservation groups amplifies environmental impact.
- **Academic Institutions:** Joint research projects foster innovation and knowledge sharing.



Real-World Use Cases and Partnerships

Corporate Carbon Offsetting

- Partnerships with Corporations: Offer carbon credits to companies aiming to reduce their carbon footprint.
- Case Study: Collaboration with a multinational firm to offset emissions through Tree NFTs

Sustainable Product Supply

- Agreements with Manufacturers: Supply Moringa-derived products to health and beauty companies.
- Case Study: Supplying Moringa oil to an organic cosmetics brand.

Renewable Energy Projects

- Biomass Energy Sales: Partner with energy companies to supply biomass fuel.
- Case Study: Providing biomass to a renewable energy facility in need of sustainable fuel sources.

Strategic Partnerships

- Technology Firms: Collaborate with blockchain and AI companies for platform enhancement.
- Environmental NGOs: Work with organizations like World Wildlife Fund for conservation efforts.
- Academic Institutions: Research partnerships for agricultural innovation.



Team



CEO - Vivek Thapar

Vivek Thapar, CEO of Green Vision, is a seasoned business executive with over 22 years of experience in corporate leadership, marketing, and IT. His passion for the environment and dedication to sustainability drive his work at Green Vision, where he combines his expertise in blockchain and digital marketing to tackle climate change through innovative afforestation projects. An advocate for reforestation and preserving ecosystems, Vivek is committed to creating a positive impact on the planet by leveraging technology to empower local communities and protect the environment.

CTO - Alex Park

Marketing Executive - Jake Gardener

Business Development - Mark Ben Basumatari

Advisors

Blockchain Advisor - Silvan Liklikuwata

Legal Advisor - Siddhant Pandey



Roadmap

Phase 1: Foundation (Q1 2023)

- Legal Framework: Establish corporate structure and secure necessary licenses.
- MVP Deployment: Scale the 4-acre Moringa plantation to demonstrate proof of concept

Phase 2: Whitepaper Launch(Q3 2024)

- Website Launch.
- Light Paper Release.

Phase 3: Token Launch (Q4 2024)

- White Paper v1.0 Release.
- Private Sale: Raise funds from strategic investors.
- Public Sale: Conduct Initial Coin Offering (ICO) for GREV tokens.
- Exchange Listings: List GREV on major cryptocurrency exchanges.
- Marketing Expansion: Launch referral programs and influencer partnerships.

Phase 4: Platform Development (Q1 2025)

- NFT Marketplace: Launch platform for NFT minting and trading.
- AI Integration: Deploy AI systems for plantation monitoring.
- Climate Combat Game Launch: Release the tapping game as part of the marketing strategy.

Phase 5: Expansion (Q2 2025 - Q4 2025)

- Land Acquisition: Secure additional land for Moringa cultivation.
- Global Partnerships: Form alliances with international corporations and NGOs.
- Scaling Operations: Expand Moringa plantations and revenue-generating activities.
- Marketing Campaigns: Intensify advertising efforts and event participation.
- Marketing Initiation: Begin content creation and social media campaigns.

Phase 6: Global Scaling (2025 onwards)

- International Projects: Initiate projects in new regions with favorable conditions.
- Platform Enhancements: Implement staking, lending, and additional DeFi features.
- Community Growth: Host events and initiatives to foster a global community.



Conclusion

Green Vision is set to redefine sustainability through cutting-edge blockchain and IoT integration. By utilizing TRON and BTTC as foundational blockchains, we ensure scalability, speed, and cost-efficiency in executing transactions and distributing carbon credits. Our multi-chain strategy, with plans for bridges across Ethereum, Polygon, Solana, XDC, Diamante and further expands asset liquidity and accessibility, allowing seamless cross-chain transfers of GREV tokens and Tree NFTs.

Our smart contracts automate critical functions like profit distribution, NFT minting, and governance, ensuring transparency, security, and real-time decision-making. In addition, AI-powered IoT sensors monitor environmental data such as tree growth and carbon sequestration, which is directly linked to our blockchain infrastructure for immutable data storage. This allows for a dynamic, verifiable record of environmental impact, accessible to all stakeholders.

Furthermore, Green Vision's use of cross-chain bridges ensures that our token economy remains decentralized and interoperable across multiple blockchain ecosystems. The integration of advanced smart contract designs enables continuous improvements, scalability, and upgradability through proxy patterns without disrupting the existing system. For investors, Green Vision offers a unique blend of financial innovation and environmental impact, providing a secure, transparent platform for generating real-world results. With a strong foundation in blockchain technology, robust partnerships, and a clear technical roadmap, Green Vision is poised to lead in the blockchain-enabled sustainability sector, merging environmental stewardship with cutting-edge decentralized solutions.



Appendix: Glossary of Technical Terms

- **Blockchain:** A decentralized ledger technology that records transactions across a network of computers.
- **NFT (Non-Fungible Token):** A unique digital asset representing ownership of a specific item or asset.
- **Smart Contract:** Self-executing contracts with the terms directly written into code.
- **Carbon Credit:** A certificate representing the reduction of one metric ton of CO₂ emissions.
- **DeFi (Decentralized Finance):** Financial applications built on blockchain technologies that operate without intermediaries.
- **DAO (Decentralized Autonomous Organization):** An organization represented by rules encoded as a computer program, transparent and controlled by organization members.
- **Layer-2 Solutions:** Secondary frameworks or protocols built on top of existing blockchain systems to improve scalability.
- **AI (Artificial Intelligence):** The simulation of human intelligence processes by machines, especially computer systems.
- **Carbon Neutrality:** Achieving net-zero carbon emissions by balancing emitted carbon with carbon offsets or elimination.
- **Multi-Chain Token:** A cryptocurrency token that exists on multiple blockchain networks.

Frequently Asked Questions (FAQs)

1. How do I participate in Green Vision?

You can participate by purchasing GREV tokens during the token sale phases and using them to mint Land or Tree NFTs on the Green Vision platform.

2. What makes Moringa trees special for this project?

Moringa trees are fast-growing and have high carbon sequestration capabilities. They also produce valuable products like leaves, seeds, and biomass, offering multiple revenue streams.

3. How are profits distributed to investors?

Profits from all revenue streams are pooled and distributed quarterly to NFT holders in stablecoins, based on the number of NFTs owned.

4. Is my investment secure?

While all investments carry risk, Green Vision employs blockchain technology for transparency and smart contracts for secure transactions. The project also has robust risk management strategies in place.

5. Can I sell my NFTs?

Yes, you can sell your Land and Tree NFTs on supported NFT marketplaces at any time.

6. How does the Climate Combat game fit into the project?

The Climate Combat game is a mobile app designed to engage users and promote environmental awareness as part of our marketing strategy. Players can earn GREV tokens and NFTs, fostering community growth.

7. What are the environmental benefits of this project?

Green Vision contributes to carbon reduction, supports biodiversity, improves soil health, and promotes sustainable agriculture practices.

8. How does Green Vision ensure regulatory compliance?

The project adheres to international environmental standards and financial regulations, including carbon credit certifications and KYC/AML policies.

9. What is the role of AI in Green Vision?

AI enhances operational efficiency by monitoring plantation health, optimizing resource use, and mitigating risks through predictive analytics.

10. How can I stay updated on project developments?

You can follow Green Vision's official channels, including the website, social media platforms, and community forums for the latest updates.

Disclaimer:

This whitepaper is for informational purposes only and does not constitute an offer or solicitation to sell shares or securities in Green Vision or any related or associated company. Any such offer or solicitation will be made only by means of a confidential offering memorandum and in accordance with applicable securities laws.

Footnotes

1. Intergovernmental Panel on Climate Change (IPCC), Special Report on Global Warming of 1.5°C, 2018.
2. United Nations Framework Convention on Climate Change (UNFCCC), Nationally Determined Contributions, 2020. [↗](#)
3. Allied Market Research, Carbon Credit Trading Market Outlook, 2021.
4. Science Based Targets initiative (SBTi), Companies Taking Action, 2021.
5. World Bank, State and Trends of Carbon Pricing 2021.
6. Taskforce on Scaling Voluntary Carbon Markets (TSVCM), Final Report, 2021.
7. Journal of Environmental Management, "Carbon Sequestration Potential of Moringa Oleifera," 2019.
8. Environmental Science Journal, "Efficiency of Moringa Trees in Carbon Sequestration," 2020.
9. Grand View Research, Superfoods Market Size & Share Report, 2020-2027.
10. MarketsandMarkets, Carbon Nanotubes Market by Type & Application - Global Forecast to 2028.
11. MarketsandMarkets, Biochar Market by Technology & Application - Global Forecast to 2025.